

**MASTER CATALOGUE**

— STYLE —

# **RETRO-VINTAGE**

**ANARIC**

**THE FINEST QUALITY**

## **The essence of the future is in everyone.**

**A essência do futuro está em cada um de nós.**

Anaric faz a ligação do tempo. Do ontem, do hoje, do amanhã. Reinventando conceitos, recuperando memórias. A busca constante pelo equilíbrio perfeito entre a disciplina, criatividade, qualidade e elegância é permanentemente gravada nos produtos Anaric.

A coleção 2014 revisita conceitos. Busca inspiração nos anos 70, num estilo retro-vintage, devidamente adaptado à modernidade e aos estilos de vida atuais.

Nesta coleção 2014 pode encontrar sofás e peças modulares, onde a nossa experiência é mais uma vez revelada nos detalhes. Modelos ideais para espaços abertos, envolvendo vários géneros e ideias globais.

Anaric makes the connection of time. From yesterday, today and tomorrow. Reinventing concepts, retrieving memories. The constant search for the perfect balance between discipline, creativity, quality and elegance is permanently engraved in Anaric products.

The 2014 collection revisits concepts. Seeks inspiration in the 70s, in a retro-vintage style, duly adapted to modernity and current lifestyles.

In 2014 collection you can find sofas and modular pieces, where our experience is once again revealed in the details. Ideal models for open spaces, involving various genres and global ideas.



## SOFAS

Andrew

Borba

Gongo

Miles

Oliver

Ryan

Tucano

Zico

Louis

## SOFAS

004-011

012-019

020-031

032-041

042-053

054-059

060-065

066-071

072-085

## ARM CHAIRS

Araci

Belmonte

Charlie

Dali

Delta

Mairi

## ARM CHAIRS

086-091

092-093

094-097

098-099

100-101

102-103

## BEDS

Jurema

Mogi

## BEDS

104-109

110-115







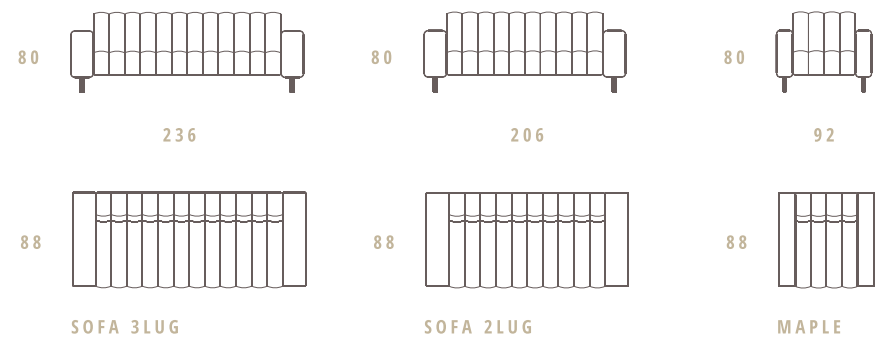



ABCDE  
FGHIJKLM  
NOPQR  
STUVWXYZ



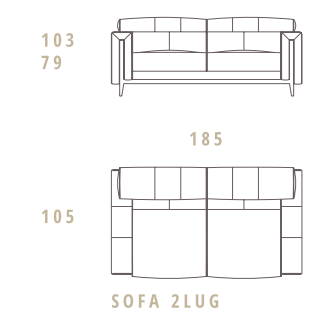
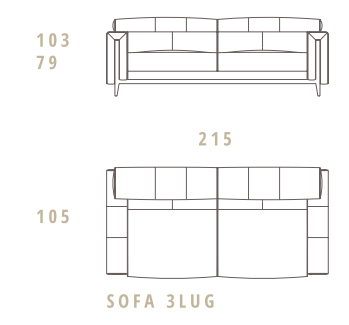
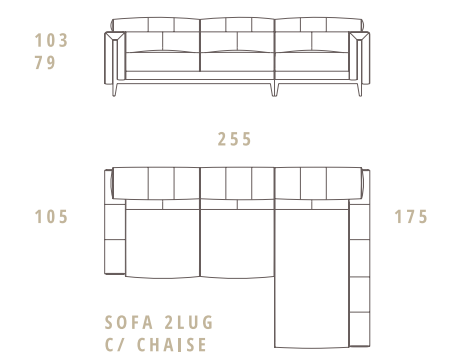
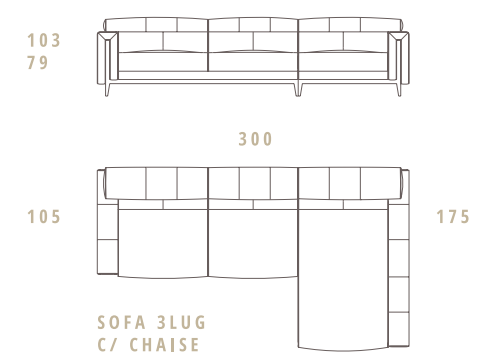







FLOWER POWER  
PARTY NIGHT



Hosted by Casey Carter & The Lotus  
SAT 28th MARCH 2008  
Live! and featuring 10 musical acts

Flower Power Party Night  
Hosted by Casey Carter & The Lotus  
SAT 28th MARCH 2008  
Live! and featuring 10 musical acts

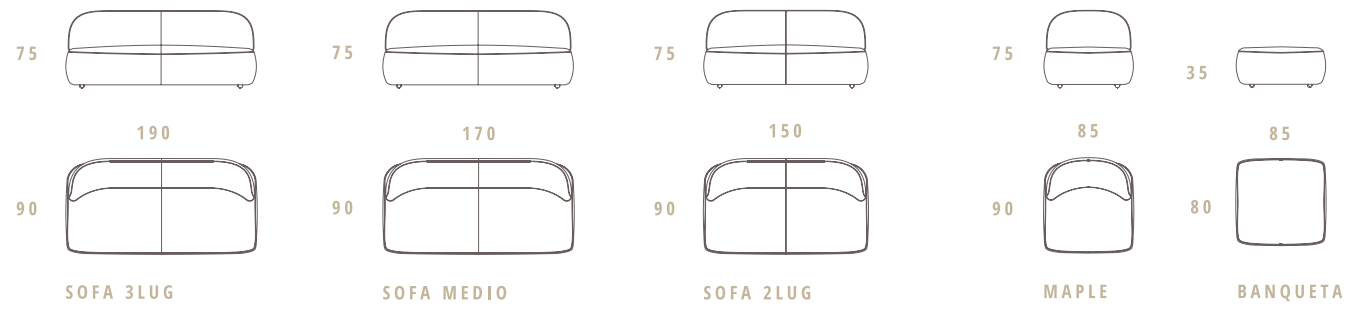



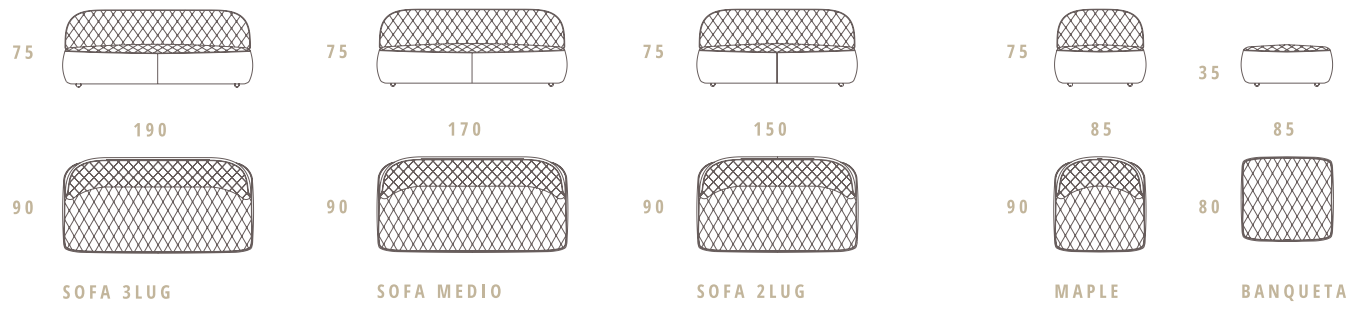











90

80

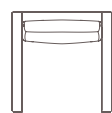

100

MAPLE



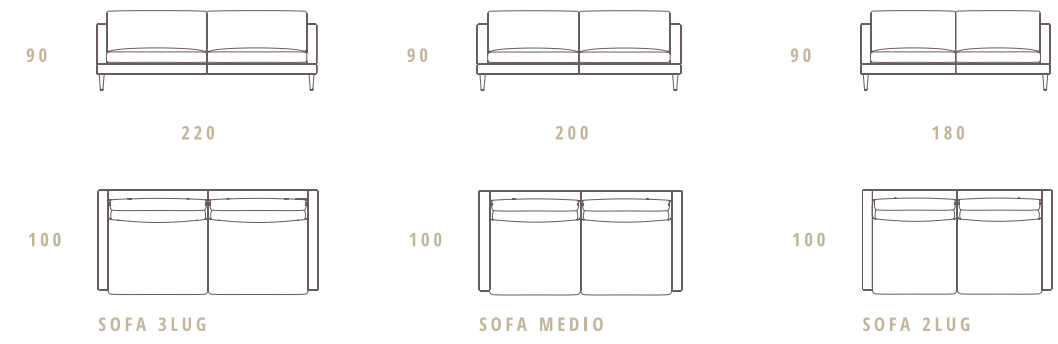



**MILES**

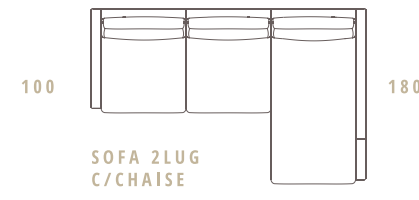
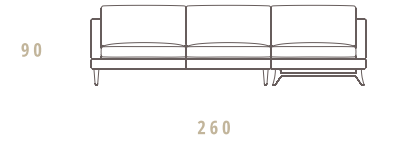
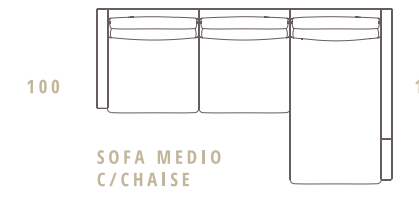
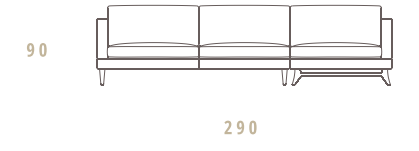
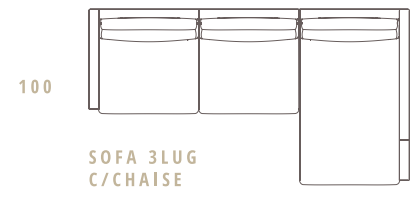
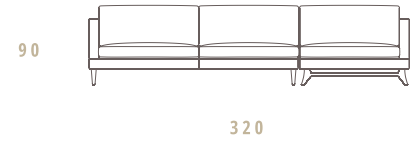







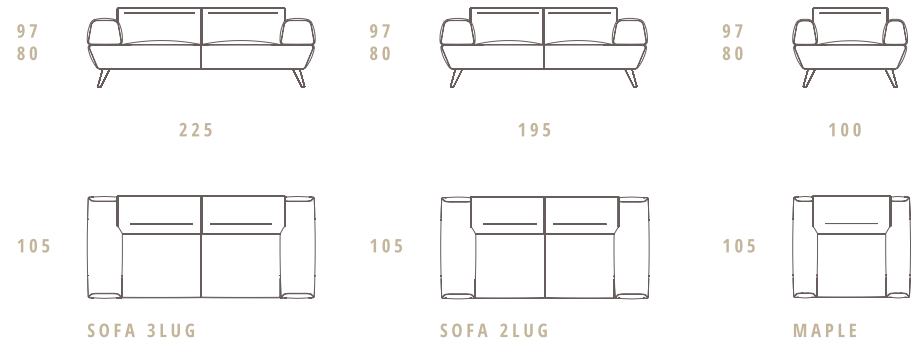





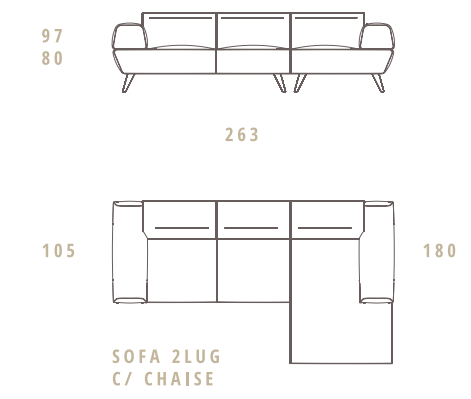
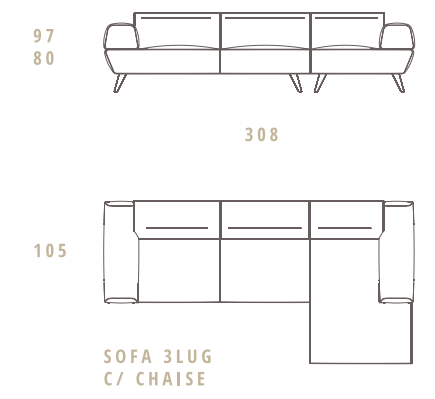



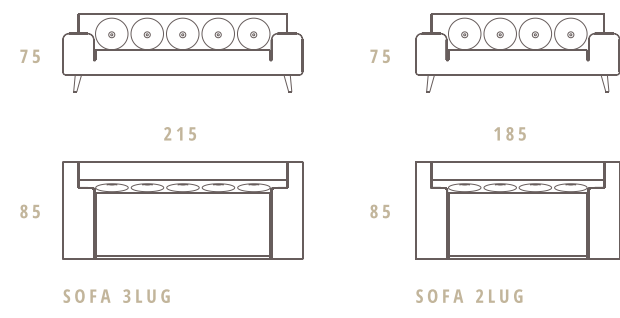

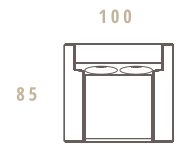
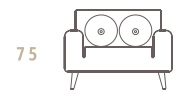

MAPLE



- 059 -

**RYAN**







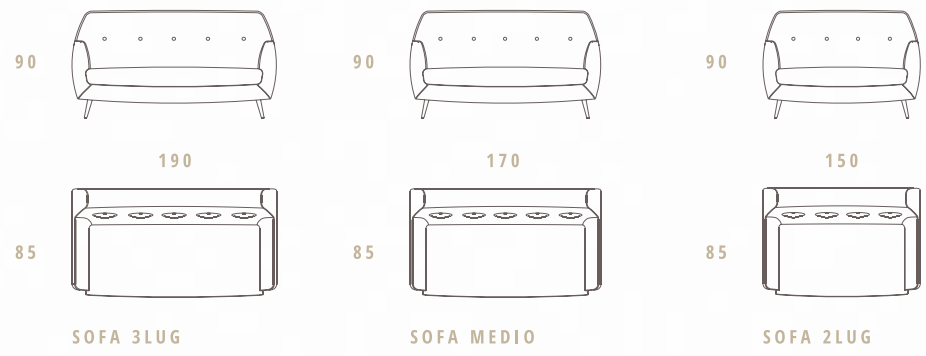

SOFA 3LUG

SOFA MEDIO

SOFA 2LUG



**TUCANO**



90

85



85

MAPLE



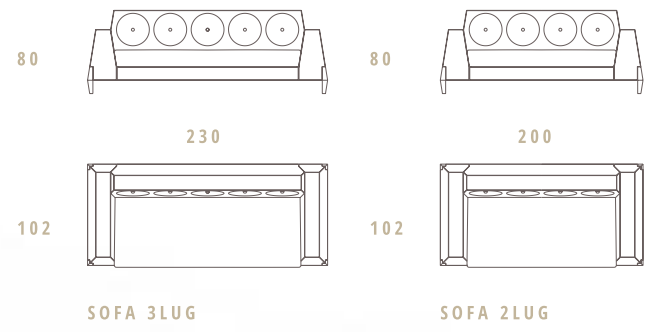

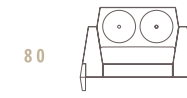

90

92

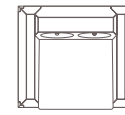

MAPLE





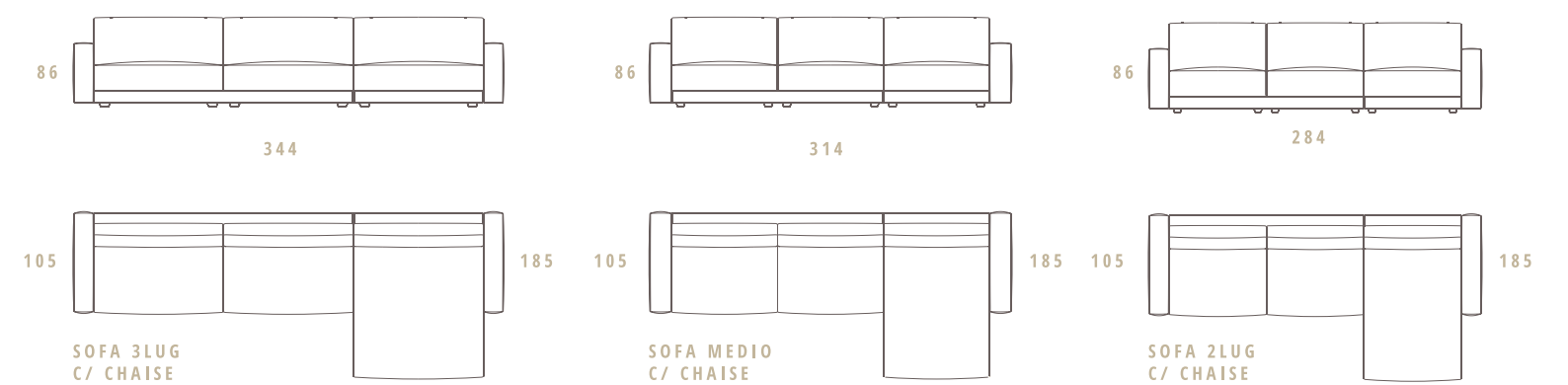
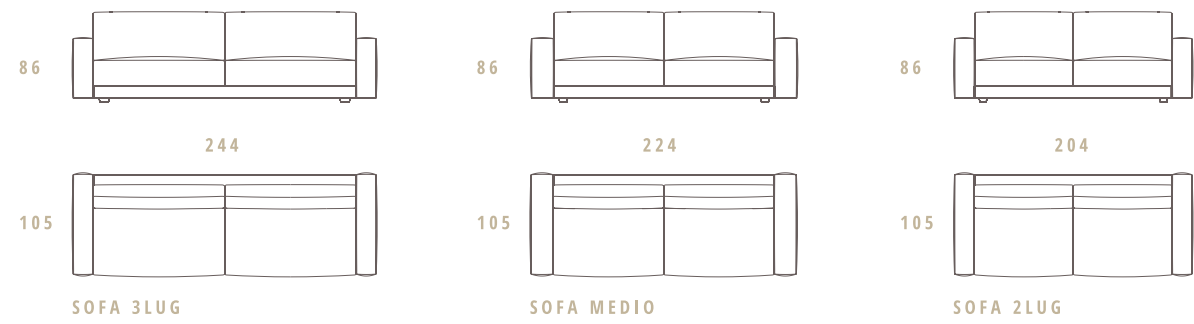











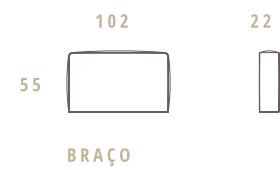
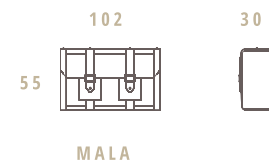
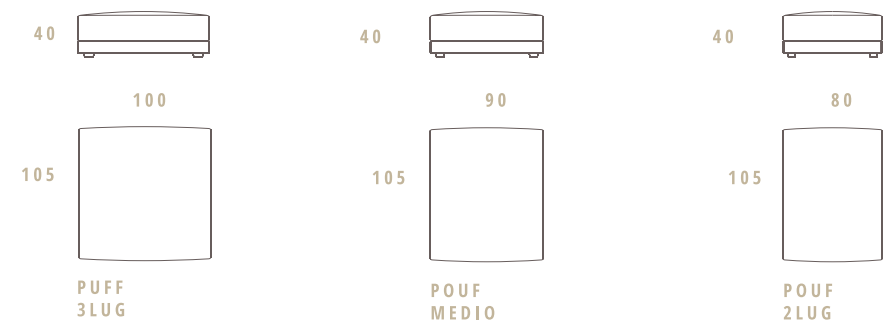
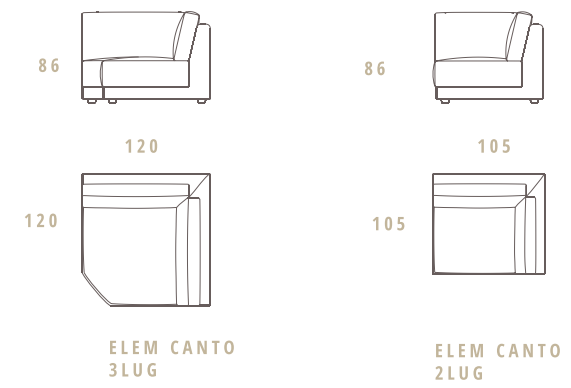
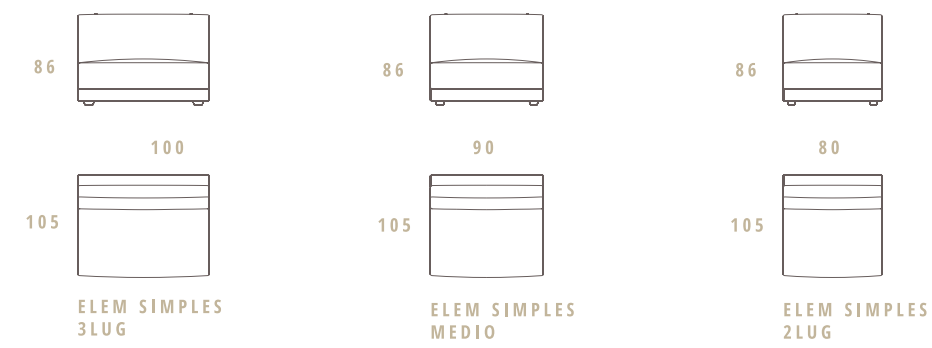
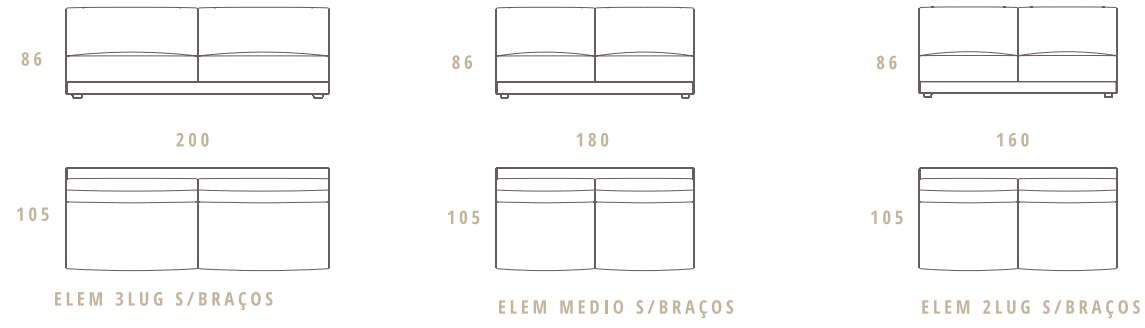
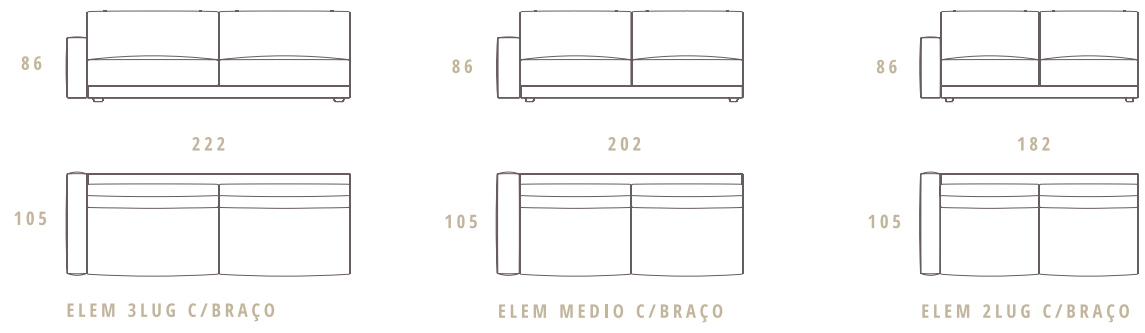

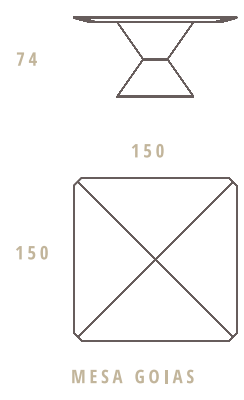

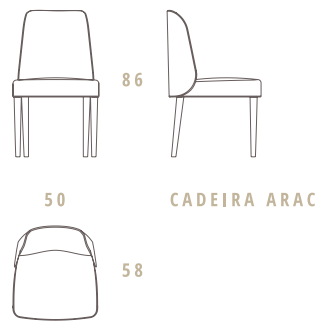

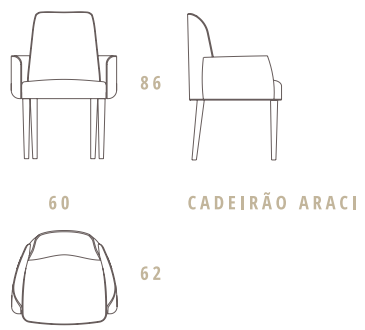

**BELMONTE**

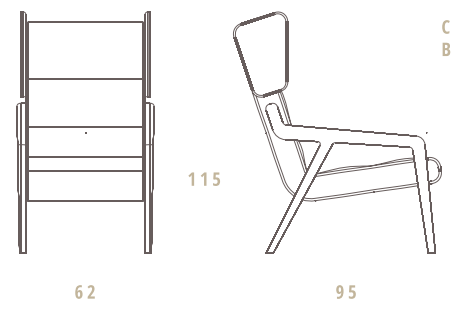

CADEIRÃO  
BELMONTE

62

115

95



**CHARLIE**

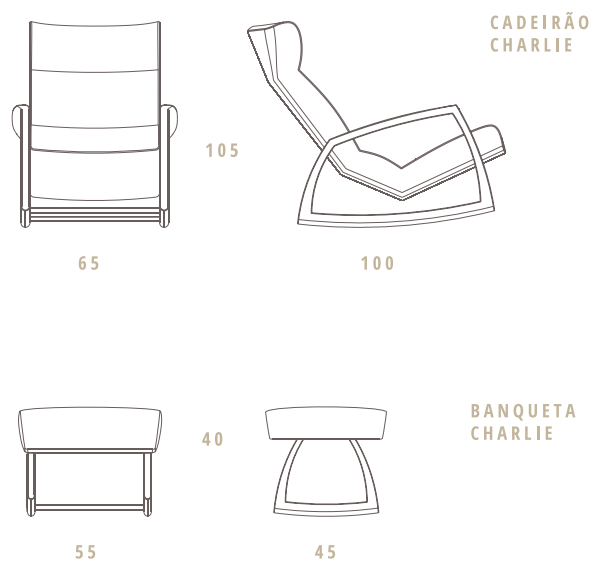

**CHARLIECAPI**

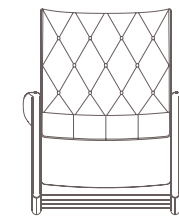

65

100

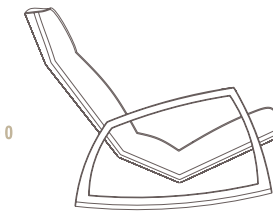

100

CADEIRÃO  
CHARLIE  
CAPI

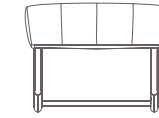

55

40



45

BANQUETA  
CHARLIE  
CAPI



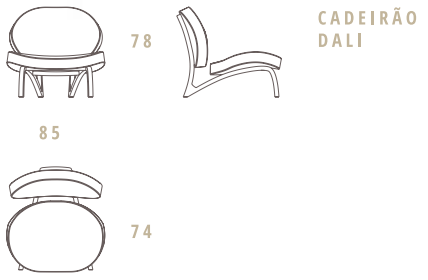

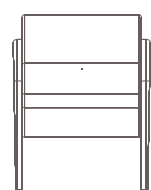

60

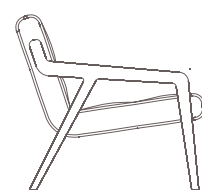

90

85

CADEIRÃO  
DELTA

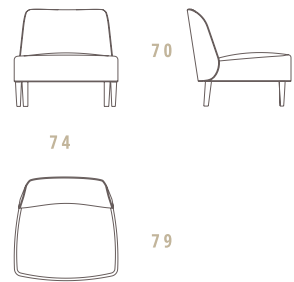

CADEIRÃO  
MAIRI





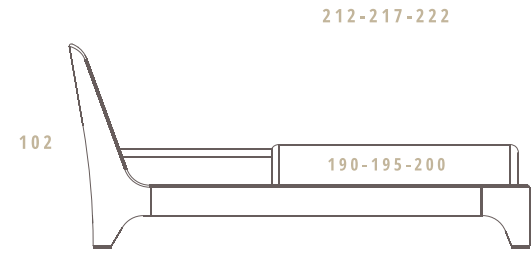
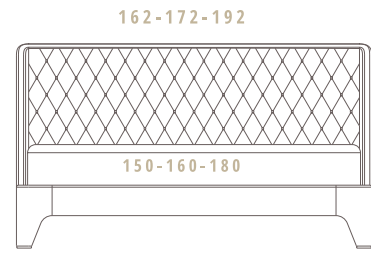

CAMA JUREMA CAPI



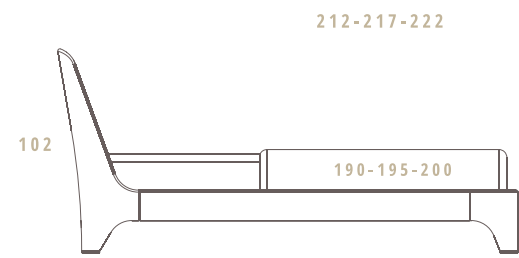
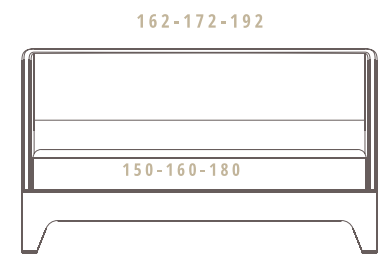

CAMA JUREMA







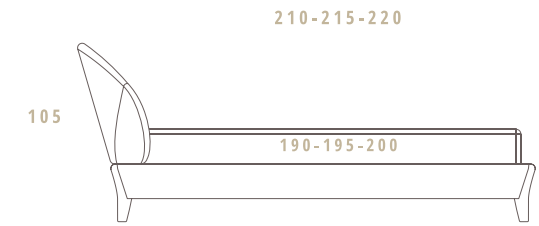
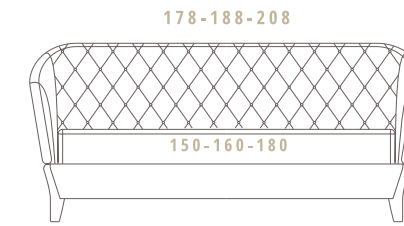

CAMA MOGI CAPI

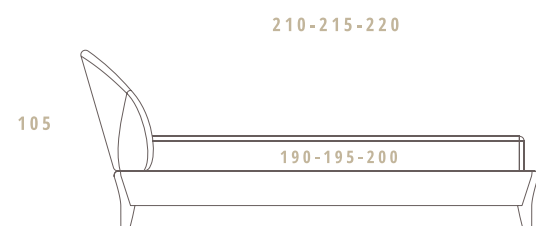
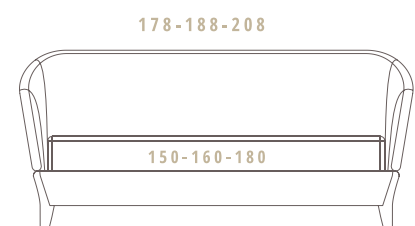

CAMA MOGI







**DESIGN PRODUTO**

Emanuel José

**DESIGN GRÁFICO**

Galliotta Design

**FOTOGRAFIA**

Carlos Ferraz

Joaquim Ferraz

**TEXTOS**

Ivo Carvalho

**IMPRESSÃO**

Rua das mimosas | Ervedosa  
4510-329 S. Pedro da Cova  
Gondomar | Portugal  
Telf. +351 22 466 4090  
Fax. +351 22 466 40 99  
anaric@anaric.pt

**ANARIC.PT**

